

# Development of Electric Propulsion Chemical Tanker with Contra-Rotating Propeller (CRP)

**FURUTA Tetsuya** : Manager, Ship & Offshore Basic Design Department, IHI Marine United Inc.

**WATANABE Manabu** : Ship & Offshore Basic Design Department, IHI Marine United Inc.

**NAKAI Genta** : Ship & Offshore Basic Design Department, IHI Marine United Inc.

**MIYABE Hiroaki** : Manager, Project Engineering Department, Engineering Division, IHI Marine United Inc.

An electric propulsion chemical tanker equipped with Contra-Rotating Propeller ( CRP ) was developed by IHI Marine United Inc. ( IHIMU ). An electric propulsion system, generally composed of diesel generators and electric motors, is apt to be less economical due to the energy loss, which arises in the electric components. To solve this problem, IHIMU adopted CRP and high efficiency hull form, both of which IHIMU has long-term experience of designing for larger vessels. As a consequence, about 5% fuel saving is expected. In spite of being a double hull tanker, this ship has as large cargo capacity as a conventional propulsion single hull tanker, thanks to smaller machinery space and reduced pump room.

## 1. Introduction

The Kyoto Protocol, which took effect in 2005, calls on Japan for a 6% reduction in the emission of greenhouse gases such as CO<sub>2</sub> by 2012 as compared to that of the base year (1990). Accordingly, a Japanese law was amended for further promotion of reductions in energy use in various fields; in the field of transportation, transportation companies and their customers larger than a certain size were bound to plan reduction in energy use and to report the amount of energy used. If the method adopted to tackle reduction of energy use is extremely poor, supervisory agencies issue recommendations, pronouncements and instructions. Thus, it has become necessary for the field of even domestic maritime transportation to develop businesses with greater awareness of environmental problems.

Social support such as a popularization and promotion system for electric propulsion vessels by an executive agency called the Japan Railway Construction, Transport and Technology Agency (JRTT) and a subsidization system for energy-saving businesses by an executive agency called the New Energy and Industrial Technology Development Organization (NEDO) is gradually being established for companies planning to build electric propulsion vessels of energy conservative type.

IHI Marine United Inc. (hereinafter called IHIMU) obtained an order for two coastal trade electric propulsion vessels by taking advantage of the aforementioned social support systems in March 2006. The two vessels were built by applying the Contra-Rotating Propeller (hereinafter called CRP) for coastal trade vessels. In

addition, the propulsion efficiency of vessels has been dramatically improved through the development of hull forms by use of the latest techniques. As a result, the electric propulsion system is able to make up for unavoidable energy losses and reduce the consumption of fuel per freight shipped in comparison with existing coastal trade vessels. This system is also expected to give rise to various advantages as a result of adopting electric propulsion.

This report presents a chemical tanker as an example and covers technical tasks, measures and advantages regarding the electric propulsion system equipped with CRP that was developed as an option for dealing with the environment in the field of domestic maritime transportation.

## 2. Outline of the vessel concerned

### 2.1 Overall plan

This vessel is a chemical tanker that domestically engages in transporting general-purpose chemical products such as benzene, toluene and xylene, boasting a tank capacity for products weighing about 1 000 tons. An existing tanker of the same size obtains propulsion through one propeller directly rotated by a low-speed diesel engine, while this vessel gathers propulsion through two propellers of CRP rotated by their corresponding electric motors. Although there is a concern with electric propulsion vessels regarding fuel efficiency due to electrical energy losses in the generator and propulsion motor as compared to existing tankers, this vessel secures better transportation economy as a result of adopting CRP and improved hull form.

This vessel is provided with three medium speed diesel generators, the parallel operation of which totally supplies electricity for its propulsion motors and other equipment onboard during normal navigation. Furthermore, when there is low demand for electricity while navigating at decelerating speed, cargo loading and so forth, the number of diesel generators in operation is reduced with a higher load factor per generator. Hence, economic operation with high fuel efficiency is made possible.

**2.2 Principal particulars of this vessel**

The principal particulars of this vessel are as follows :

Overall length (approx.)	64.80 m
Length between perpendiculars	61.80 m
Breadth	10.00 m
Design draft	4.20 m
Gross tonnage (domestic)	499 t
Propulsion motor	370 kW × 2
Diesel generator (medium speed diesel generator)	350 kW × 3
Service speed (at 70% capacity)	10.5 kn
Cargo pumps (motor-driven deepwell type)	100 m <sup>3</sup> /h × 8

An outline of the general arrangement is shown in Fig. 1. The engine room has become compact, and cargo pumps of motor-driven deepwell type have been adopted (a type that directly drives a pump in a tank through a shaft by a motor positioned above the tank). A pump is provided for each tank, thereby reducing the pump room volume in comparison to the existing vessel. As a result, even though this vessel adopts a double-hull structure, it can secure as large a cargo space as an existing single-hull vessel.

**3. Electric propulsion system**

**3.1 Outline of the electric propulsion system**

The electric propulsion system of this vessel consists of two sets of a propulsion motor, an inverter, a transformer for electric noise reduction and a braking resistor. Figure 2 and Table 1 show the configuration of the electric propulsion system and the main specifications of the system respectively.

Inverters of PWM (Pulse Width Modulation) type are adopted for the variable speed control system of propulsion motors, contributing to high-precision control. This vessel is equipped with transformers for electric noise reduction in order to reduce the harmonic noise made by these inverters. Furthermore, regenerative electric power (electric power generated due to the motor operating as a generator), which arises when the braking is applied through reversing propellers, is absorbed by braking resistors.

**3.2 Electricity distribution system**

Table 2 shows the demand for electricity during the navigation of this vessel. During normal navigation, electricity is supplied for the electric propulsion system and other equipment onboard through the parallel operation of three diesel generators. Should this vessel be navigated without one of the three diesel generators due to breakdown or maintenance, the remaining two diesel generators have sufficient capacity to drive the propulsion motors for navigation.

**3.3 Measures against noise**

The system concerned adopts PWM inverters; however, an inverter of this type causes harmonic noise during the phase of switching, possibly resulting in motor overheating and electronic appliances malfunctioning. Thus, in order to reduce the harmonic noise in the system concerned, transformers for electric noise reduction are equipped to reduce the distortion factor of the voltage waveform in the power supply voltage.

**3.4 Regenerative electric power**

As brakes are applied by the rotation of the propellers being switched from normal to reverse during forward

**Table 1** Main specifications of electric propulsion system

Name of equipment	Quantity	Specifications
Main diesel generator	3	350 kW, 1 200 min <sup>-1</sup> , 450 V, IP22, 60 Hz, 3φ
Propulsion motor	2	370 kW, 1 200 min <sup>-1</sup> , IP44, F class insulation, continuous rating, with sea water cooled air cooler
Inverter	2	370 kW, PWM inverter, H class insulation, IP22
Transformer for electric noise reduction	2	500 kVA, 440 V/440 V - 440 V( Three-winding ), 3φ, H class insulation, IP22

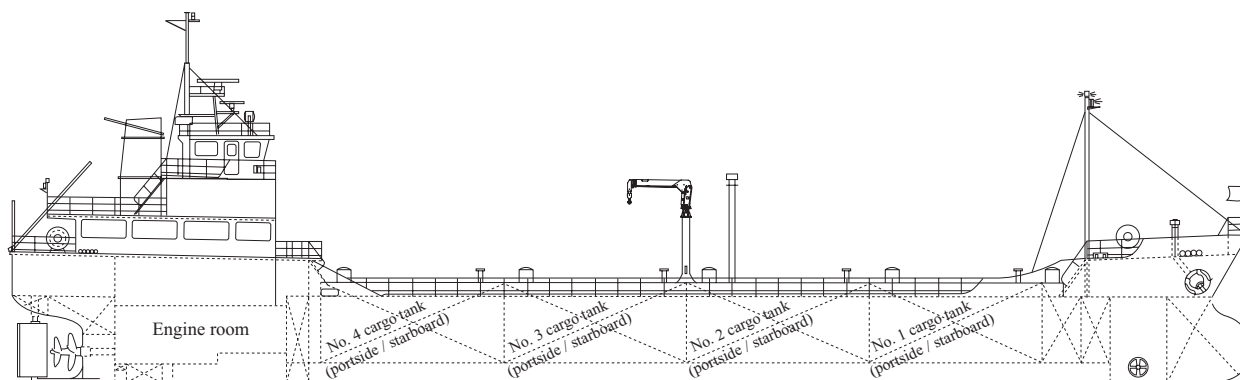

**Fig. 1** General arrangement

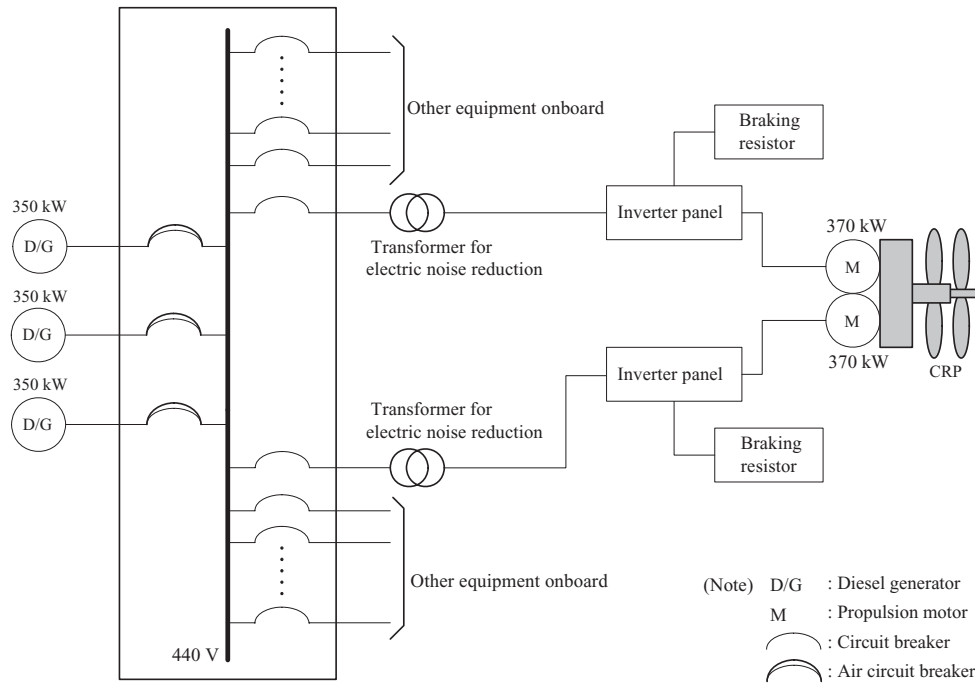

Fig. 2 Configuration of electric propulsion system

Table 2 Demand for electricity

Items	During normal navigation	In time of maximum power output	Operation with reduced number of generators
Electricity for electric propulsion system*1 (kW)	560	820	490
Electricity for other equipment onboard (kW)	140	140	140
Total electricity (kW)	700	960	630
Number of diesel generators in operation	3	3	2
Load factor on diesel generator (%)	67	92	90

(Note) \*1 : Efficiency of the electric propulsion system is taken into account.

navigation, the propulsion motors act as induction generators giving rise to regenerative electric power. Two methods of absorbing this regenerative electric power are presented below.

(1) Dynamic braking

Letting regenerative electric power flow to the resistor and having it consumed as heat

(2) Regenerative braking

Returning regenerative electric power to the electric power source system and having the load factor in the system consume it

Since this vessel has no load factor in the system of electric power source to consume regenerative electric power as illustrated in **Table 2**, it adopts (1) Dynamic braking to induce the braking resistor to absorb regenerative electric power.

3.5 Protection control

For the protection of equipment as well as in case of power failure onboard, this vessel carries out the following controls.

(1) Load reduction control

When diesel generators in operation bear an excessive load due to an operation mistake or a sudden stoppage of a diesel generator, the whole power generation system might halt and power failure follows onboard. In order to avoid this problem, load reduction control automatically reduces the number of revolutions made by propulsion motors, and decreases the load on the diesel generators.

(2) Control of maximum torque limitation

When load on the propellers fluctuates due to rough weather or turning of the vessel, the propulsion motors and inverters may bear excessive load. In order to avoid this problem, control to limit the power output of the motors within a fixed torque is carried out.

4. Contra-Rotating Propeller (CRP)

4.1 Outlines of the CRP system

CRP, which consists of two contra-rotating propellers positioned in tandem, is a thrust system in which the aft propeller recovers lost energy due to rotating flow occurring behind the fore propeller and changes it to thrust, and furthermore high propelling efficiency can be obtained by the assignment of thrust to two propellers and the reduction of the load borne by each of them.

The whole arrangement of the electric motor-driven CRP system is shown in **Fig. 3**. The CRP system of this vessel starts with the power output transmitting shafts of the two propulsion motors positioned side-by-side, driving torque is transmitted to both the aft and fore propellers by allowing the two-step reduction gear with parallel input to rotate the inside and outside shafts independently.

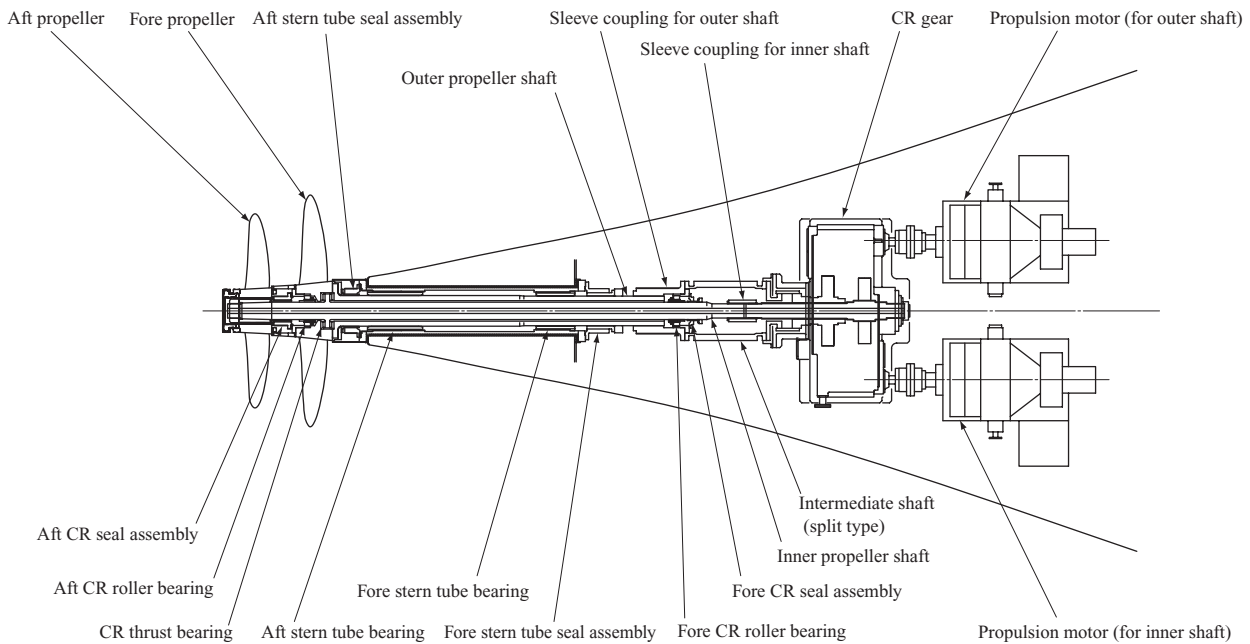

Fig. 3 Arrangement of electric motor driven CRP system

#### 4.2 Improvement of the existing system

IHIMU had been engaged in developing and delivering the CRP system aimed for large-size commercial vessels even before IHI Corporation (hereinafter called IHI) became split.<sup>(1), (2)</sup> To promote the use of electric propulsion and facilitate the assembly at a shipyard in the CRP system of this vessel, the following improvements are being made to the existing system.

- (1) Securing redundancy in the system due to promoting the use of electric propulsion

The star-type epicyclic gear directly coupled with a low-speed diesel engine has been adopted for the existing contra-rotating gear for large size commercial vessels. However, this vessel adopts the contra-rotating reduction gear with twin input from the twin propulsion motor for the following reasons: ① double shaft input system with two propulsion motors being positioned side-by-side and ② necessity of reduction due to high revolutions of the motors.

The inner and outer shafts are independent of each other from the input all the way to the propeller output. Thus, redundancy comes into play in order to secure continuous navigation by use of one propulsion shaft system should malfunctioning of the other shaft occur.

- (2) Facilitating the assembly at a shipyard

In order to facilitate the assembly at a shipyard, the CRP system from a coupling with CR gear output to an outer propeller is delivered as a finished unit after being assembled on the ground. Therefore, at the shipyard the CRP unit is connected with the CR gear and so forth, which have already been installed onboard, after being brought in from the aft part of the stern tube. Unitization makes it

possible to install a complex CRP system with ease without specialist know-how.

In addition, a sleeve coupling and a split type outer intermediate shaft are adopted for a coupling with CR gear output so that the assembly can be readily performed, reducing the number of assembly tasks performed inside the small engine room of a typical coastal trade vessel.

#### 5. Machinery arrangement

The shaft-related assembly and propulsion motors are positioned at the stern side in the machinery space, and three diesel generators side-by-side at the bow side. These pieces of equipment are seemingly surrounded by a sea water pump, fuel pumps, LO pumps, coolers and so on. The machinery arrangement is shown in Fig. 4.

#### 6. Development of hull form

In developing the hull form of this vessel, the objective has been to reduce the horsepower required for propulsion to less than that for existing coastal trade vessels by applying the know-how accumulated at IHIMU to forms of coastal trade vessels.

Capabilities of the hull form adopted for this vessel were confirmed through model tests using a towing tank, which large-size commercial vessels undergo. An experiment was performed with a model ship provided with a contra-rotating propeller to simulate flow field generated by CRP.

#### 7. Features acquired through promoting the use of electric propulsion

After such phases as design and experiment, the following features are expected to be acquired through promoting the use of electric propulsion for this vessel, a domestic chemical tanker.

- (1) An existing domestic chemical tanker boasts a

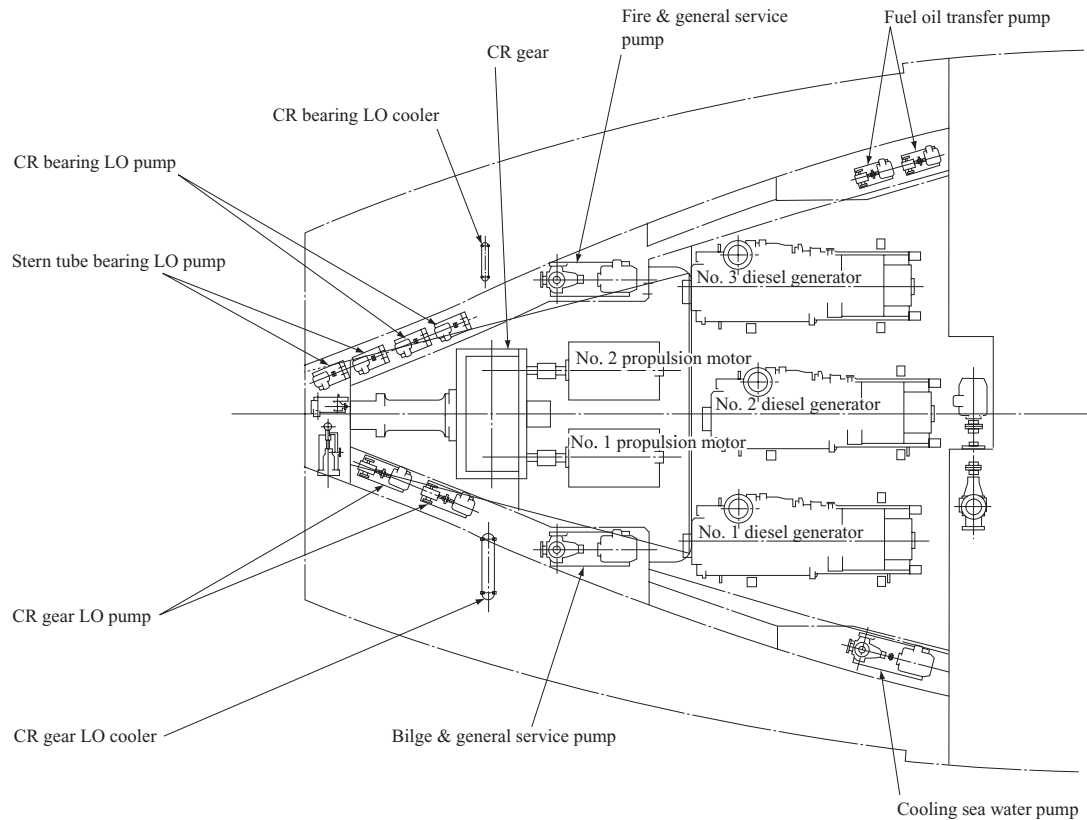

Fig. 4 Machinery arrangement

main engine and two diesel generators, whereas this vessel has three diesel generators of the same type. Thus, spare parts can be used interchangeably, facilitating easier maintenance operations.

- (2) A conventional propulsion system consists of one main engine and one propeller; this vessel has two motors and two propellers. The two separate propulsion systems give rise to high redundancy and raise operational reliance.
- (3) The fuel consumption of this vessel has been reduced by about 5% per ton of freight and transportation mile as compared to existing vessels. Reduced fuel costs are expected.
- (4) Emissions of  $\text{NO}_x$  and  $\text{CO}_2$  are reduced by about 35% and 5% respectively as a result of adopting medium-speed diesel generators by this vessel instead of low-speed engines.
- (5) Vibration and noise in the accommodation space decrease as a result of adopting medium-speed diesel generators in comparison with low-speed engines. Living conditions for crews are expected to improve.

## 8. Conclusion

IHIMU, taking advantage of the aforementioned features, would like to engage in sales in the field of domestic

electric propulsion vessels on which there is potentially great demand; at the same time, it is committed to modernizing domestic maritime transportation through developing and supplying still more efficient electric propulsion systems as well as adopting the use of super conducting motors now in the process of development carried out by IHI as a center player.

### — Acknowledgments —

IHIMU are grateful to the staff of Kokuho-Kisen Co., Ltd., Uyeno Transtech Ltd. and the Japan Railway Construction, Transport and Technology Agency, which provided the opportunity and gave advices in developing this vessel.

### REFERENCES

- (1) Shipbuilding & Offshore : Voyage Reports and Appraisal on CRP-Ship "JUNO", Ishikawajima-Harima Engineering Review Vol. 31 No. 4 July 1991 pp. 258 - 263
- (2) Y. Sakamoto, R. Fujino, K. Katsumata and T. Narita : "Okinoshima Maru" 258 000 DWT Contra-Rotating Propeller Tanker, Ishikawajima-Harima Engineering Review Vol.34. No. 5 Sept. 1994 pp. 372 - 377