

# Flatness Control System of Cold Rolling Process with Pneumatic Bearing Type Shape Roll

**TSUZUKI Shigeru** : Manager, Control System Engineering Department, IHI Metaltech Co., Ltd.

**KIRA Yoichi** : Manager, Control Department, IHI Metaltech Co., Ltd.

**MISUMI Kenji** : Manager, Machinery Engineering Department, IHI Metaltech Co., Ltd.

The automatic flatness control system, IHI Sheetflat, has been applied to many cold rolling mills since 1985. The pneumatic type shape roll is used as the shape sensor. Recently, requirements for quality products have become much more important. Therefore, performance of the shape roll has also been improved to meet the requirements. Strip shape is evaluated based on the Fourier's analysis method, and the shape error is corrected by mill actuators. Shape data are sampled for the whole strip length and stored in a computer, which are available as quality management data. Effectiveness of control performance is verified in rolling very thin foils. The number of reference plants using IHI Sheetflat has been increasing continuously.

## 1. Introduction

Flatness control in rolling processes is widely used for steel and nonferrous metals, such as aluminum and copper. We developed a shape roll by applying the principle of pneumatic bearing and supplied the first flatness control system (hereinafter called IHI Sheetflat) to an aluminum cold rolling mill in 1985.<sup>(1)</sup> Since then, IHI Sheetflat has been adopted by many customers inside and outside Japan. We have supplied a total of 72 stands of systems and manufactured 76 pneumatic bearing type shape rolls (including those being designed and manufactured as of December 2008).

This paper introduces the recent achievements of the pneumatic bearing type shape rolls and the control system as the basic technologies of IHI Sheetflat.

## 2. Pneumatic bearing type shape roll

### 2.1 Shape of rolled material

**Figure 1** shows examples of the strip shape. The shape is made by the relation between the cross-sectional profile (also referred to as the crown) of the material and the profile of the gap between mill rolls. If the material is rolled uniformly and elongated evenly over the strip width, it has a flat shape (**Fig. 1-(a)**). If the material is not evenly elongated, it has wavy patterns (**Fig. 1-(b)** and **-(c)**) in the parts that are too elongated.

The material being rolled is wound up under tension and at high speed. It is difficult to visually check the shape of the material, and various kinds of shape sensors have been developed.<sup>(2)</sup> For cold rolling processes, there have been many reports about the use

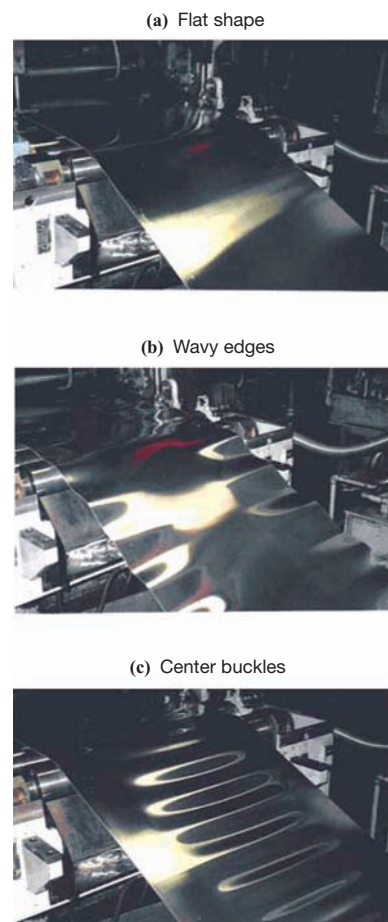

**Fig. 1** Strip shape

of pneumatic bearing or other contact roll types of shape rolls. <sup>(3), (4)</sup>

The strip shape is usually defined in terms of steepness or relative difference in elongation as shown in Fig. 2 <sup>(1)</sup> and equation (1). We use I-UNIT, <sup>(5)</sup> which is based on the relative difference in elongation of  $1 \times 10^{-5}$ , as the unit of shape.

$$\lambda = h_i / l_i \times 100\%$$

$$\varepsilon = \Delta l_i / l_i \doteq (\pi / 2 \times h_i / l_i)^2 \dots\dots\dots (1)$$

- $\lambda$  : Steepness
- $\varepsilon$  : Relative difference in elongation
- $h_i$  : Height of wave generated by difference in elongation
- $l_i$  : Standard length
- $\Delta l_i$  : Difference in elongation

Figure 3 shows a schematic diagram of the relationship between strip shape and relative difference in elongation. When a rolled material is cut in a longitudinal direction, the wavy piece is longer than the standard length  $l_i$  by  $\Delta l_i$ . This ratio is the relative difference in elongation as shown in equation (1). The tension distribution along the strip width of this material during rolling is higher in the center part, and becomes lower in both edges with larger waves. In this way, there

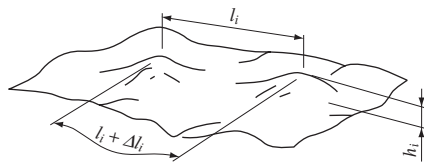
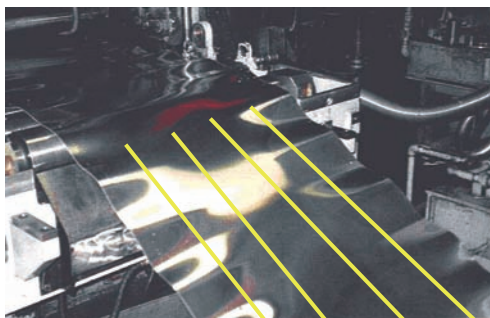

Fig. 2 Definition of strip shape <sup>(1)</sup>



Cut in the longitudinal direction

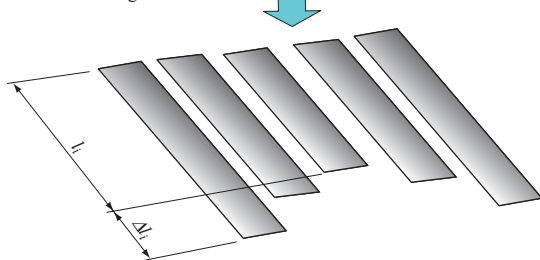

Fig. 3 Relationship between strip shape and relative difference in elongation

is a correlation between the severity of wave patterns and the relative difference in elongation and the tension distribution. This means that we can determine the shape by checking the tension distribution.

**2.2 Shape roll utilizing the principle of pneumatic bearing**

A pneumatic bearing has no friction in principle and it is used for bearings of high-speed rotating shafts, such as spindles of machine tools, and plane bearings for transportation of heavy objects. The load applied to a bearing can be determined by measuring the pneumatic pressure of the bearing surface. These characteristics are applied to the shape rolls.

**2.2.1 Principle of the shape roll**

Figure 4 shows the configuration of a pneumatic bearing type shape roll. Compressed air blows out of the nozzles on the cylindrical shaft (arbor) and generates an air film between the arbor and the rings (rotors) mounted externally to form a pneumatic bearing. The pressure of the air film is in balance with the rotor load, and this causes a pressure difference between the (upper) pressure port on the load side and the (lower) pressure port on the antiloading side. By measuring this pressure difference for each rotor, we can determine the load distribution and thereby determine the tension distribution along the strip width.

Pneumatic bearing type shape rolls have the following features:

- ① High sensitivity (able to detect a change in load smaller than 0.1 N)
- ② Capability to continuously detect the shape.
- ③ Low rotation resistance owing to rotors supported by the pneumatic bearing.
- ④ Simple structure eliminating the need to use auxiliary drives.

So they are widely adopted in finishing cold rolling mills and foil rolling mills for aluminum, copper and other materials.

**2.2.2 Basic data of shape roll**

- (1) Dimensions of the shape roll

Each rotor has a diameter of 160 to 180 mm (standard 180 mm) and a width of 25 to 100 mm (standard 50 mm). The rotor width and the

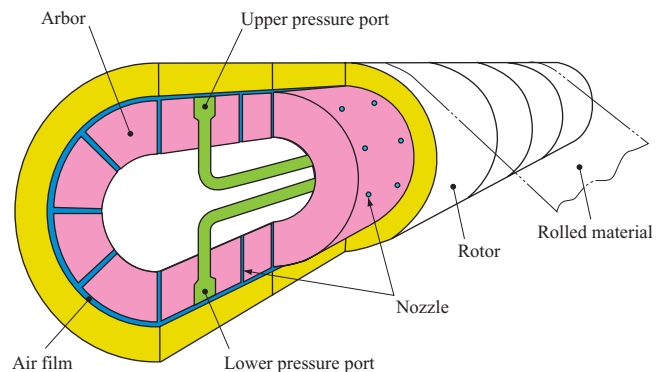

Fig. 4 Configuration of pneumatic bearing type shape roll

number of rotors are determined depending on the specifications of the material to be rolled. It is also possible to combine rotors with different widths.

(2) Wrap angle of material

Figure 5 shows the wrap angle of a material on the shape roll. The wrap angle  $\theta$  is determined by considering the maximum load applied to the rotor and the shape sensing resolution.

Equation (2) shows the relationship between the force applied to the rotor ( $F$ ), the tension and wrap angle of the rolled material. The maximum value of wrap angle is determined so that  $F$  is kept less than the maximum load even if tension is concentrated on a certain rotor because of a shape defect.

$$F = 2 \times UT \times W \times T \times \sin(\theta/2) \dots\dots\dots (2)$$

- $F$  : Force applied to the rotor ( N )
- $UT$  : Unit tension of material ( N/mm<sup>2</sup> )
- $W$  : Rotor width ( mm )
- $T$  : Material thickness ( mm )
- $\theta$  : Wrap angle ( ° )

Equations (3) and (4) show the difference in unit tension along the strip width caused by defective shape of  $\epsilon$  I-UNIT ( $\Delta ut$ ) and the difference in load between rotors ( $\Delta f$ ) respectively.

$$\Delta ut = \epsilon \times 10^{-5} \times E \dots\dots\dots (3)$$

$$\Delta f = 2 \times \epsilon \times 10^{-5} \times E \times W \times T \times \sin(\theta/2) \dots\dots (4)$$

- $\Delta ut$ : Difference in unit tension in the strip width ( N/mm<sup>2</sup> )
- $\epsilon$  : Relative difference in elongation indicated in I-UNIT
- $E$  : Young's modulus ( N/mm<sup>2</sup> )
- $\Delta f$  : Difference in load between rotors ( N )

Generally, the shape sensing resolution should be less than 1 I-UNIT of relative difference in elongation. The minimum value of wrap angle is determined so that the shape roll can stably detect  $\Delta f$  caused by this relative difference in elongation.

(3) Arrangement of shape roll

Figure 6 shows examples of arrangement of a shape roll. In a foil rolling mill (for a material with a thickness of 0.006 to 0.5 mm), a shape roll is fixed as shown in Fig. 6-(a) and a wrap angle is adjusted

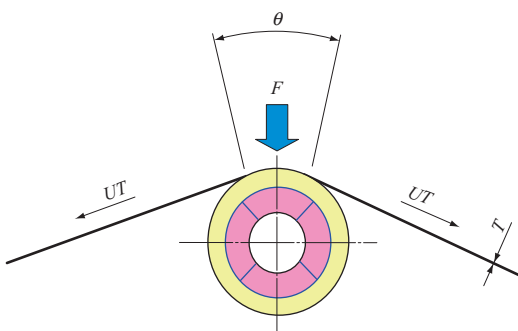

Fig. 5 Strip wrap angle on shape roll

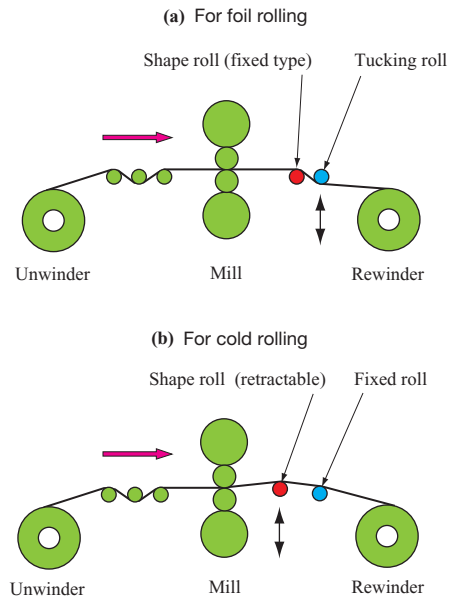

Fig. 6 Arrangement of shape roll

by changing the height of the tucking roll. In a cold rolling mill where the material is thicker and the tension is higher compared with a foil rolling mill, a retractable shape roll is adopted as shown in Fig. 6-(b). This configuration can reduce the wrap angle and thereby reduce the load applied to the shape roll.

(4) Recent improvement in shape roll technology for higher quality

Table 1 shows the recent improvement in shape roll technology for higher quality. There have been severer customer demands regarding the quality of rolled products year by year. To respond to them, we have made efforts to improve the quality of the shape rolls. Figures 7 and 8 show a shape roll with shifting device and 25 mm wide rotors developed for higher sensing accuracy. Figure 7 also shows the inline calibration jig designed to improve maintainability.

3. Automatic shape control system

During rolling, mill roll profile is subject to changes because of deflection and thermal expansion and thereby the shape of the material varies constantly. Conventionally, skilled operators checked the shape and adjusted mill actuators manually to maintain a stable shape. This has been replaced by an automatic shape control that has a closed loop of a shape roll and a rolling mill as shown in Fig. 9. This has enabled high-speed and stable rolling without relying on operator skills.

3.1 Shape analysis

Figure 10 shows the concept of shape analysis. The average rolling tension and the tension deviation for each rotor are determined from the load applied to each rotor. This deviation is considered as a periodic

**Table 1** Recent improvement in shape roll technology

Item	Developed technology	Feature
Sensing accuracy	Accurate rotor	The rotor manufacturing process was improved to reduce the signal fluctuation during no-load rotation to less than half of the conventional value.
	Shift type shape roll	This keeps edges of a rolled material on the rotors to enable shape sensing over the entire width.
	25-mm wide rotor	This enables more detailed shape measurements for highly accurate shape sensing on edges of rolled material.
	High-sensitivity sensor	This sensor has a differential pressure transducer sensitivity that is twice as high as the conventional one to improve the shape sensing resolution.
Product quality	Brush roll	This is used for removing powder attached to rotors.
	Low-inertia rotor	This rotor has a thinner wall to reduce the rotation inertia by 30 percent compared with the conventional value and improve the ability to follow the rolled material.
Maintainability	Inline calibration jig	This enables shape roll calibration without removing from the mill.

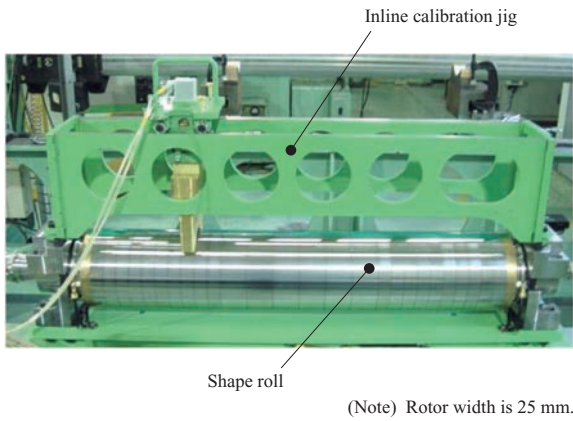

**Fig. 7** Shape roll ( narrow rotor type ) with inline calibration jig

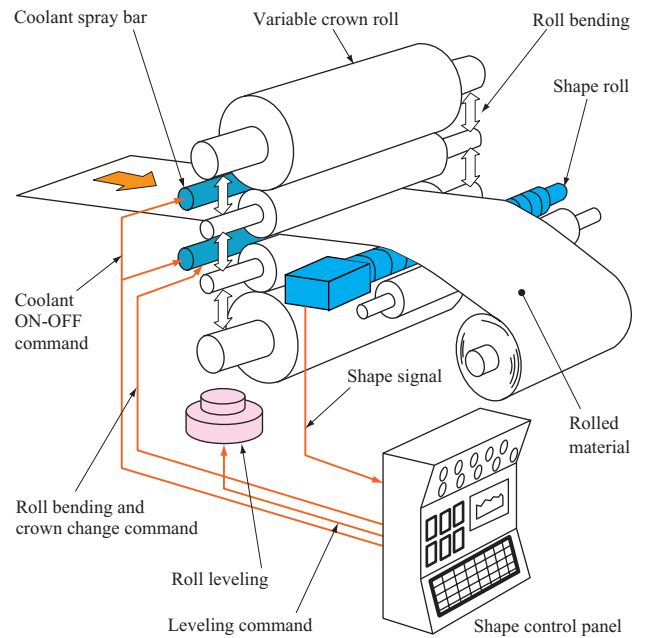

**Fig. 9** Configuration of automatic shape control system

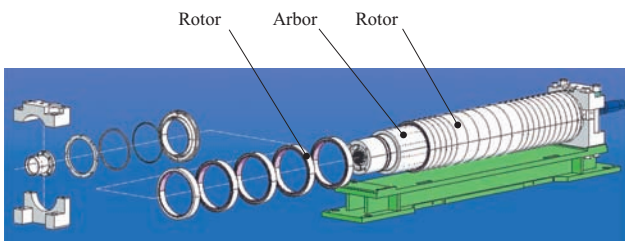

**Fig. 8** Shape roll ( narrow rotor type ) assembly

function, and the Fourier's series expansion is applied to cosine components by taking a strip width as one period. The general formula of the Fourier's series expansion is given in equation (5).

$$f(x) = \sum_{n=1}^{\infty} (A_n \cos(nx) + B_n \sin(nx)) + \frac{A_0}{2}$$

$$A_n = \frac{1}{\pi} \int_0^{2\pi} f(x) \cos(nx) dx$$

$$B_n = \frac{1}{\pi} \int_0^{2\pi} f(x) \sin(nx) dx$$

..... (5)

In equation (5), the magnitude of the primary cosine

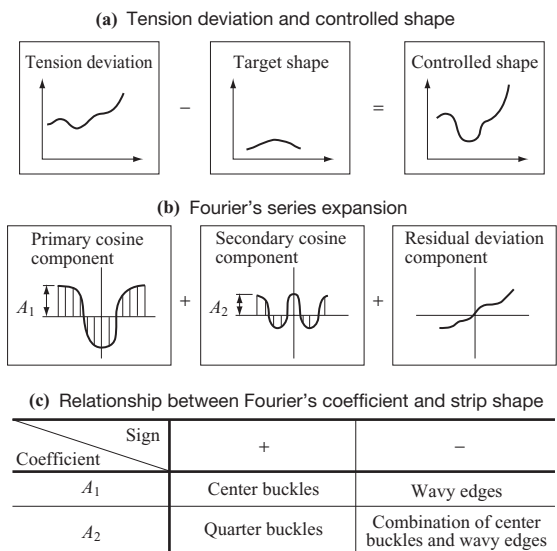

**Fig. 10** Concept of shape analysis

component,  $A_1$ , refers to the center buckles or wavy edges ; and the magnitude of the secondary component,  $A_2$ , refers to the quarter buckles or the combination of center buckles and wave edges of the material.

**3.2 Shape control**

Strip shape is controlled by operating the shape control actuators of the rolling mill based on the analysis results. High-response roll bending and/or variable crown roll are used to control the Fourier's series components  $A_1$  and  $A_2$ . Unsymmetrical components and residual deviation are individually analyzed and modified by the roll leveling and the zone coolant control utilizing partial roll thermal expansion.

Accurate shape control can also be achieved by applying a coolant at a different temperature in addition to the ordinary coolant.

**Figure 11** shows the simulation of the zone coolant control with different temperature. It shows the calculation results of the temperature change and the thermal expansion displacement on the roll surface with application of the coolant at a temperature of 60°C over

the entire width of the mill roll and application of the high-temperature coolant at 83°C to a certain part.

**3.3 Control equipment**

Strip shape is controlled by repeating a series of operations, including shape detection, analysis and control output, using a computer. **Figure 12** shows the configuration of a shape control system.

In a cold rolling process, materials are processed at a maximum speed higher than 30 m/s, and changes in strip shape are steadily determined and controlled by making calculations every 0.05 second from shape detection to control output. The shape data is recorded for the entire length of the material and can be utilized for playback of the control state as shown in **Fig. 13-(a)** and shape classify as shown in **Fig. 13-(b)** for quality control. The control operation software is written in a general programming language so that the user can add or change the program according to their operation.

**3.4 Control performance**

**Figure 14** shows an example of shape control for final rolling of aluminum foils. The thickness after rolling is

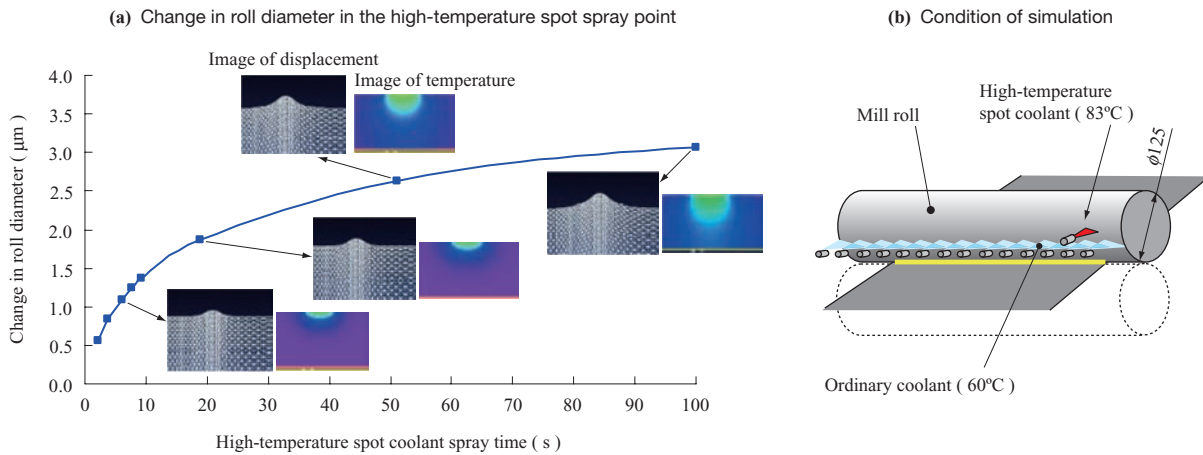

**Fig. 11** Simulation of zone coolant control with different temperature ( unit : mm )

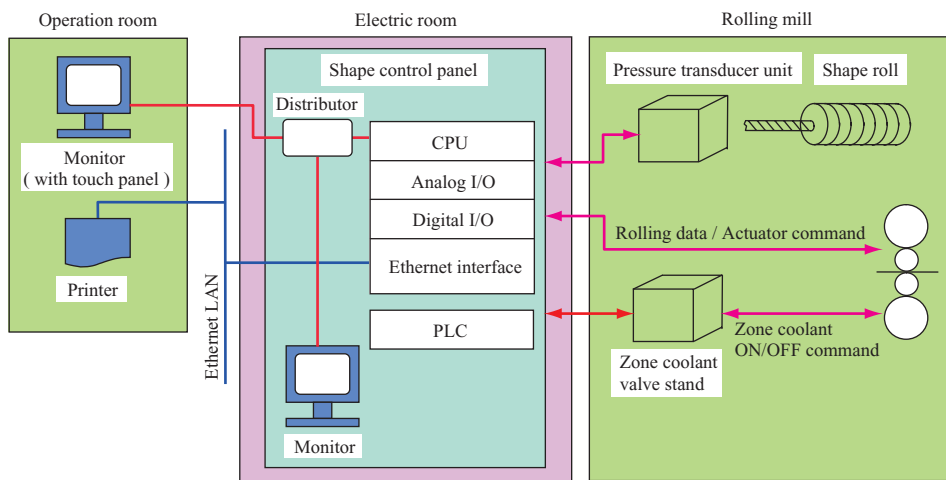

(Note) PLC : Programmable Logic Controller

**Fig. 12** Configuration of shape control system

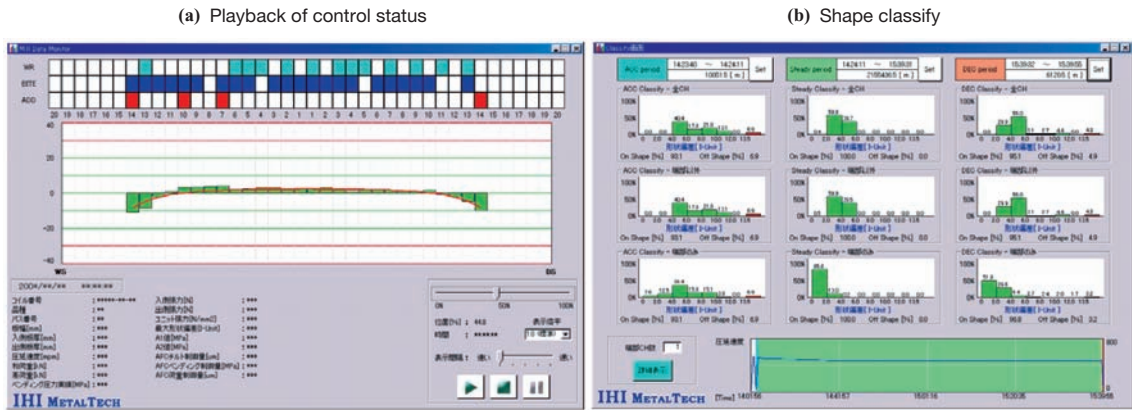
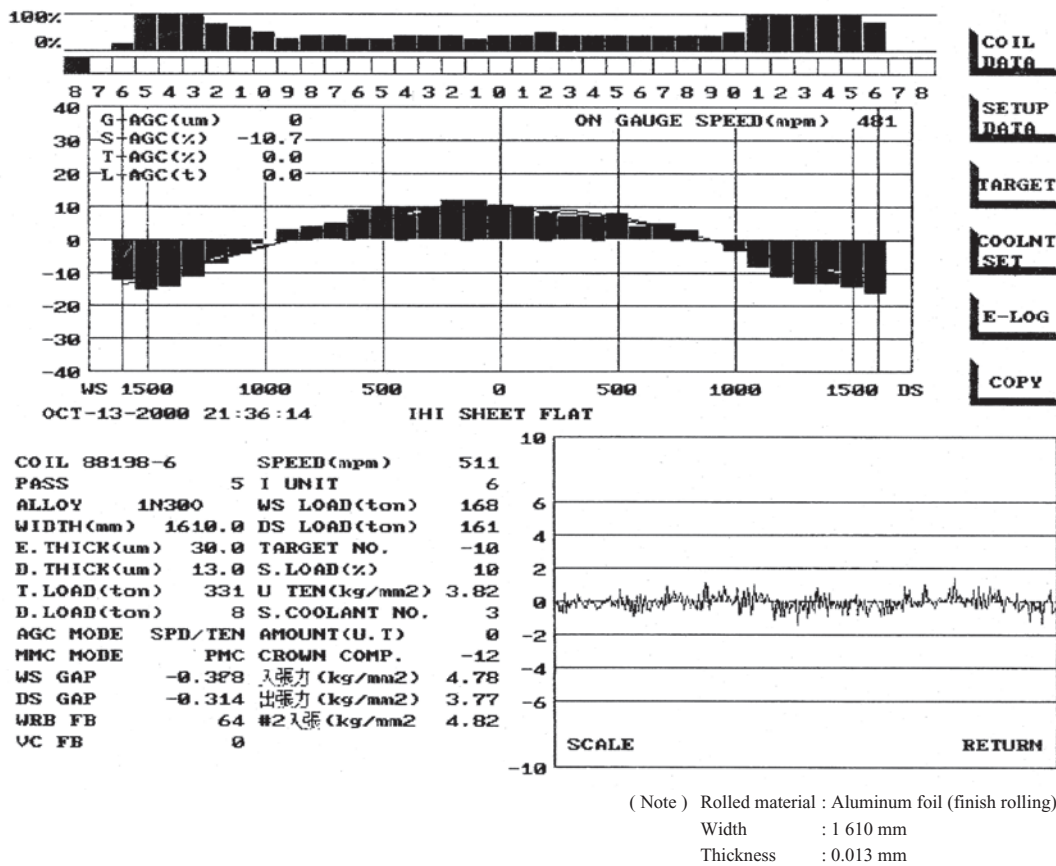

Fig. 13 Screen sample of shape data review



(Note) Rolled material : Aluminum foil (finish rolling)  
 Width : 1 610 mm  
 Thickness : 0.013 mm

Fig. 14 Example of shape control performance

0.013 mm, composed of two 0.006 5 mm thick layers. Such a very thin foil is often rolled with wavy edges to prevent the material from breaking during rolling. The example in the figure shows a rolling operation with target wavy edges of 30 I-UNIT. The control accuracy at steady speed rolling is kept within 6 I-UNIT.

#### 4. Conclusion

This paper has outlined the pneumatic bearing

type shape rolls and the control system as the basic technologies for the shape control system (IHI Sheetflat) in cold rolling processes. Because of their high degree of detection accuracy, pneumatic bearing type shape rolls are widely applied to cold rolling and foil rolling mill for aluminum and copper. The automatic shape control system with a closed loop of a shape roll and a rolling mill contributes to stable production of high-quality products.

Process speed will increase and rolled products will be made thinner and stronger in the future. We will continue to further improve the IHI Sheetflat functions to accurately meet customer needs.

#### REFERENCES

- (1) H. Kato, T. Seki, M. Nitanda and K. Higuchi :  
Development of The Automatic Flatness Control  
( AFC ) System of Strip Shape, IHI Engineering  
Review Vol.20 No.3 ( 1987. 7 ) pp. 110-114
- (2) The Iron and Steel Institute of Japan :

- Handbook for Iron and Steel, CD-ROM 4th ed.  
Vol.3 No.1 ( 2002 ) Section 8.8.4.c
- (3) The Japan Society for Technology of Plasticity e.g :  
The 133rd Japanese Symposium for the Technology  
of Plasticity ( 1990. 12 ) pp. 42-43, p. 55
  - (4) The Japan Institute of Light Metals e.g :  
Profile and Flatness Control of Aluminum Sheet  
No.27 ( 1992. 8 ) p. 19, p. 21 ( Japanese )
  - (5) The Iron and Steel Institute of Japan : Theory and  
Practice of Flat Rolling ( 1984. 9 ) pp. 266-270