

IHI Shape Control Equipment for Strip and Plate Rolling Mill

HONJO Hisashi : Senior Engineer, Machinery Engineering Department, IHI Metaltech Co., Ltd.
SATO Masayoshi : Manager, Machinery Engineering Department, IHI Metaltech Co., Ltd.
KUCHI Masahiro : Manager, Machinery Engineering Department, IHI Metaltech Co., Ltd.

Various types of shape control actuators for strip and plate rolling use are used worldwide (“shape” here means both strip flatness and strip crown). IHI has also supplied some types of shape control actuators for hot and cold rolling mills in ferrous and nonferrous fields according to customer’s requirements and conditions. These IHI shape control actuators are described and the characteristics explained along with fields in which they are applied and their performance. Today, IHI mainly supplies roll shifting actuators for shape control in hot steel rolling, for use with specially selected roll ground curves.

1. Introduction

Various types of shape control actuators for strip and plate rolling (in this paper, “shape” means both strip flatness and strip crown), which are used to control shapes in strip and plate rolling, have been developed and put into practical use. The required specifications and configurations of the actuators vary depending on the customer-specific production and equipment conditions.

IHI has delivered various types of shape control actuators for strip and plate rolling according to customer-specific requirements. These shape control actuators are still used as production equipment and the performance of many of them has been reported. The authors intend to further meet the needs of their customers and to summarize IHI shape control actuators for strip and plate rolling in this paper.

2. Shape control actuators

2.1 Roll bending methods

A work roll bending device (hereinafter called WRB) is, because of its usability and easy-to-install structure, the most commonly used shape control actuator for strip and plate rolling. Although the ideal WRB load capacity is a little less than one-tenth of the rolling load, it is, in many cases, difficult to achieve this ideal load even if WRB is combined with negative bending to enhance total WRB load.

A double chock bender (hereinafter called DCB) method, equipped with two chocks at a roll neck of work roll, is an effective WRB method which is able to easily achieve a balanced design among the three strength constraint conditions – roll strength, bearing strength, and chock strength – and obtain a large bending

capacity in a limited space. However, these types of rolls have roll axis ends that slightly protrude and cannot easily be installed by converting an existing mill ; they should be initially installed when a new mill is installed.

WRB has a relatively simple structure, and is often installed with other shape control actuators. **Figure 1** shows an example of the reported control characteristics ⁽¹⁾ obtained when DCB is installed with a VC roll, which is to be explained in **Section 2.3**. In the figure, the mechanical center crown value indicated on the vertical axis represents the difference in strip thickness between the strip center and strip

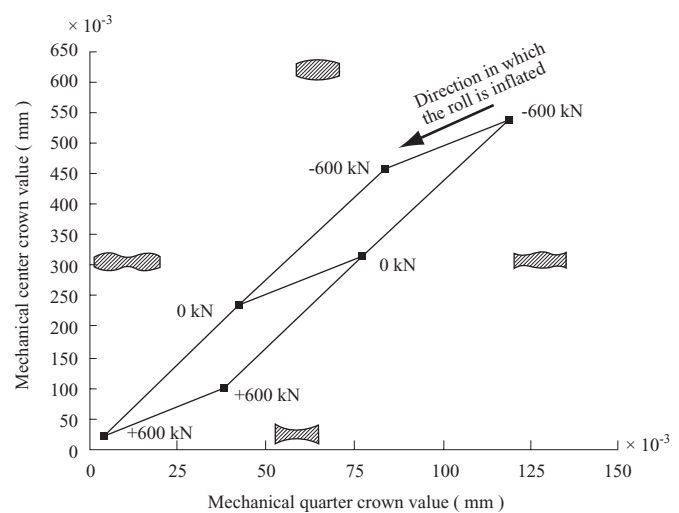

(Note) 1. Numerical values in the figure indicate a DCB force.
 2. Conditions
 · Strip width : 1 600 mm
 · Rolling force : 11 620 kN

Fig. 1 Control characteristic of VC rolls with DCB ⁽¹⁾

edge when the rolling force is distributed evenly in the width direction, while the mechanical quarter crown value indicated on the horizontal axis represents the difference in strip thickness between the strip center and strip quarter width position.

Because a highly responsive hydraulic system is required to apply bending loads, the direct-drive servo valve developed by IHI is adopted in some cases. Although it is difficult to use negative bending with many rolling mills that often require threading and tailing out, the usability of negative bending in threading and tailing out can be improved by adopting a highly responsive servo valve with a short pipe length between valve and cylinder.

Small diameter work rolls are effective in reducing the rolling load in rolling extremely thin strips and hard materials. However, in the WRB method, by which a roll is bent at its end, the bending effect does not transmit well to the roll center region.

It is possible to additionally install support rolls, which come in contact with a work roll, to support it at the roll barrel length, in order to provide bending and support effects. One kind of bending (support) roll, in addition to the main support roll that vertically supports the rolling load, is designed to push the work roll in an oblique or horizontal direction. In some cases, a shape control method is adopted in which the specific portions of the work roll barrel are hydraulically and selectively pushed (FFC method) by the bending rolls, as shown in Fig. 2. (2)

For rolling mills with a long barrel, as a method of bending a work roll, an outboard bending mechanism is installed at the back-up roll to bend the large diameter

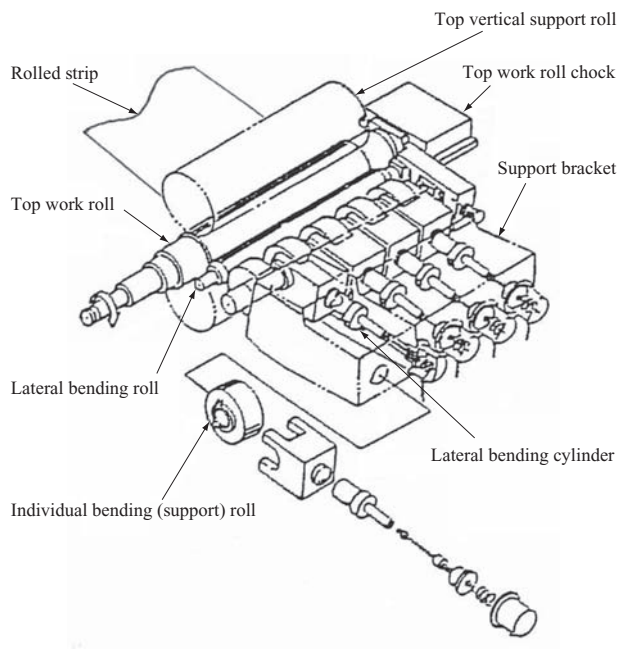

(Note) Shape control: FFC method

Fig. 2 Lateral bending (support) mill

back-up roll and indirectly bend a long barrel work roll. Figure 3 shows the estimated mechanical center crown control effect of each rolled strip width with an outboard back-up roll bending device (hereinafter referred to as "BURB") installed in a plate mill for hot steel rolling (3) (work roll diameter is 1 020 mm, back-up roll diameter is 1 830 mm, and barrel length is 4 700 mm). Figure 3 shows the mechanical center crown control effect of each rolled width with WRB. It can be seen from Fig. 3 that when the strip width is large, the control effect of WRB is greater than that of BURB; however, when the plate width is small, the control effect of BURB is greater than that of WRB.

With multi-high rolling mills (for examples, six-high rolling mills), it is possible to equip the large diameter intermediate roll with a vertical bending function to indirectly bend a work roll. The intermediate roll bending method and back-up roll bending method can be used without being affected by the complicated WRB pressure control required for changing work rolls, strip threading and tailing out.

2.2 Roll shift method

Various roll shift shape control methods have been reported in Japan and overseas, and these methods are basically classified (4) into ① a method by which the shape control effect can be improved by shifting rolls, reducing the contact portion between rolls outside the strip width as a result, to improve the deflection of the rolling rolls (Fig. 4), and ② a method by which the shape control effect can be improved by shifting specially shaped rolls, and producing the geometric roll gap distribution change effect in the width direction (Fig. 5).

IHI has handled various roll shift methods, and found that the method based on the effects of geometrically shaped shift rolls shown in Fig. 5 is advantageous in that the shape control effect can be freely set by the

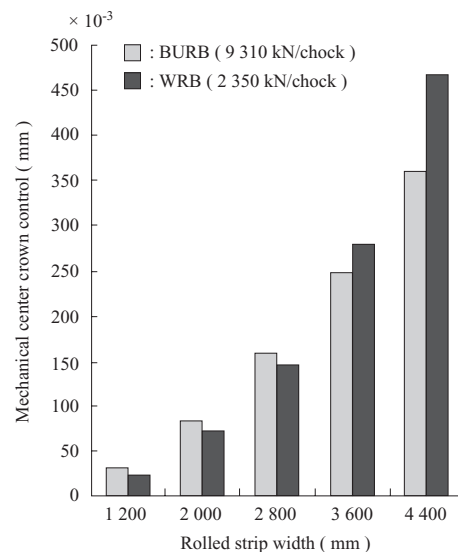

Fig. 3 Mechanical crown control range

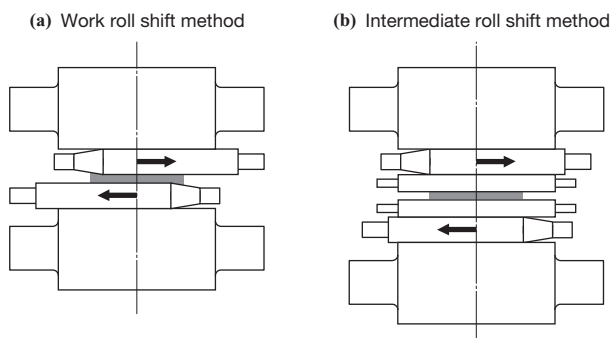

Fig. 4 Shape control with adjustable roll contact length

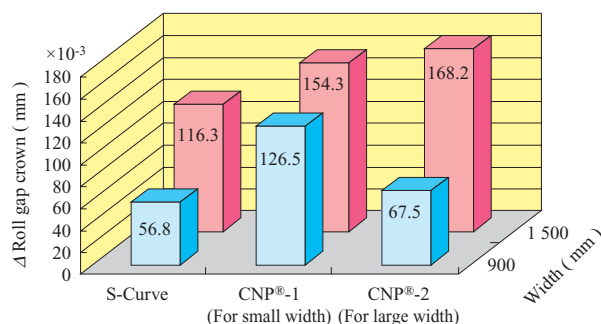

Fig. 6 Strip crown controllability of CNP® Mill⁽⁶⁾

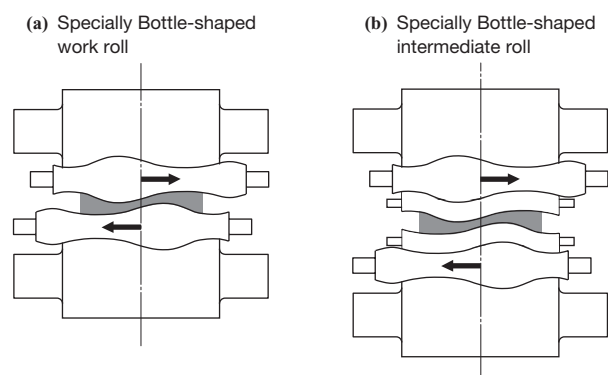

Fig. 5 Shape control with specially curved shift rolls

geometric shape. The prevailing NC roll grinding machine has made it possible to more freely set the grinding roll curve, and more easily improve the effect of the optimized roll curve.

Basically, the same shift mechanism is used in the above-mentioned methods ① and ②, and IHI proposes to the customers the geometric shape most appropriate to the customer’s production and equipment conditions (an example of the optimization methods is shown in the “Patent Published Number”⁽⁵⁾). IHI has been improving usability at the customer site by delivering an automatic setting system that simultaneously calculates the setting values for the shift positions and rolling bending pressures and provides commands, according to the roll shape. IHI refers to such an optimally-shaped shift roll as a CNP® (Combined Numerical Profile) roll.

To promote the optimization of shift roll shapes, the roll shape of each rolling mill plant or rolling mill stand can be optimized, and the shape of shift rolls of a rolling mill stand can be optimized one by one so that the control effect for the strip width with a higher production ratio becomes greater. Figure 6⁽⁶⁾ shows a comparison of the strip crown shape control effect of each strip width, between a rolling mill with an optimally-shaped shift roll (CNP® roll), and a rolling mill with a roll profile having simple concave and convex combined curve (S-shaped curve). To thoroughly optimize the roll shape, the shape is often determined not by using specific functions, but by using numerical data.

Figure 7 shows the result of the strip crown controllability test with such a specially shaped roll installed in the final finishing hot strip mill stand. In Fig. 7, the “strip crown Cr25” on the vertical axis represents the difference in strip thickness between the strip width center and a position 25 mm inward from the strip width end in the width direction.

The work roll shift method can also be used for roll wear dispersion to reduce step wise uneven wear on rolls in hot steel rolling. Table 1 and Figs. 8, 9 and 10 show examples of roll wear dispersion tests with hot strip mills. For these tests, CNP® rolls were ground to a shape similar to wear that occurs after 100 strips (calculated based on the wear formula) are rolled, and were installed. Using these rolls, 65 coils were actually rolled with F5 and F6 stands performing a cyclic roll shift. Adjacent F5 and F6 stands performed a shift oscillation in opposite directions, and rolled these coils while preventing variations in strip crown due to wear dispersion roll shift. Even when the strip width of a

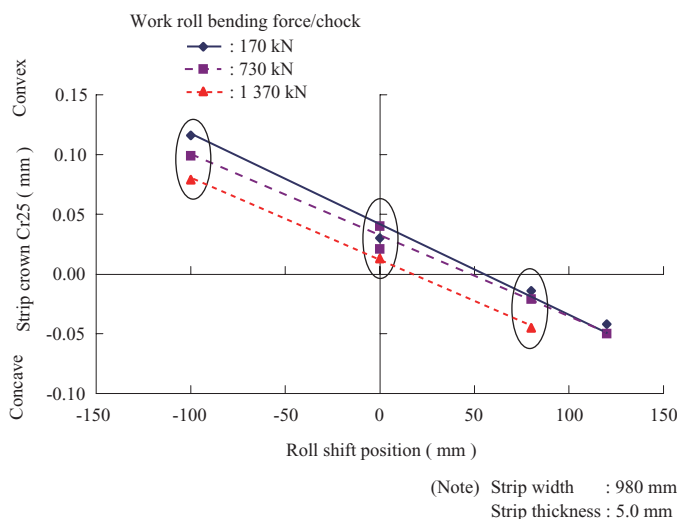
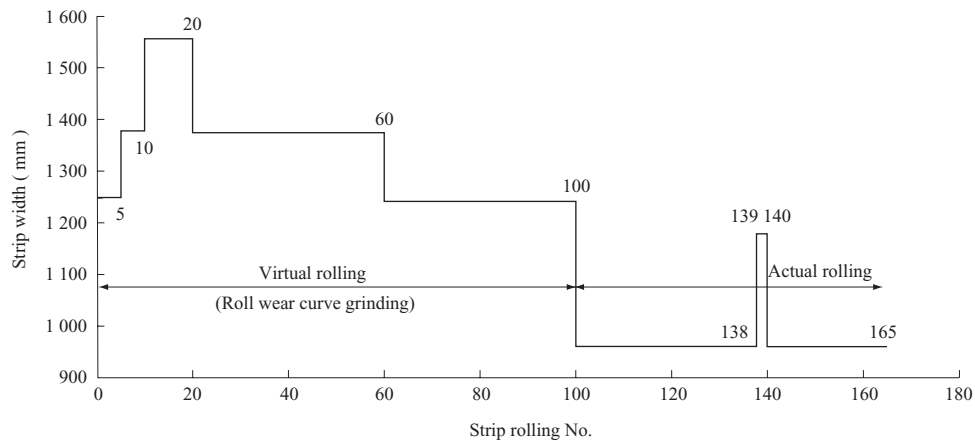

Fig. 7 Measured strip crown controllability by CNP® Mill

Table 1 Rolling pass schedule for roll wear dispersion tests

Stand No.	F1	F2	F3	F4	F5	F6	F7
Strip thickness at the exit (mm)	50.0	22.7	12.7	7.8	5.0	3.7	2.8



(Note) Rolling mill : $\phi 760/\phi 1380 \times 2032$ mm, hot strip mill

Fig. 8 Rolling schedule for roll wear dispersion tests

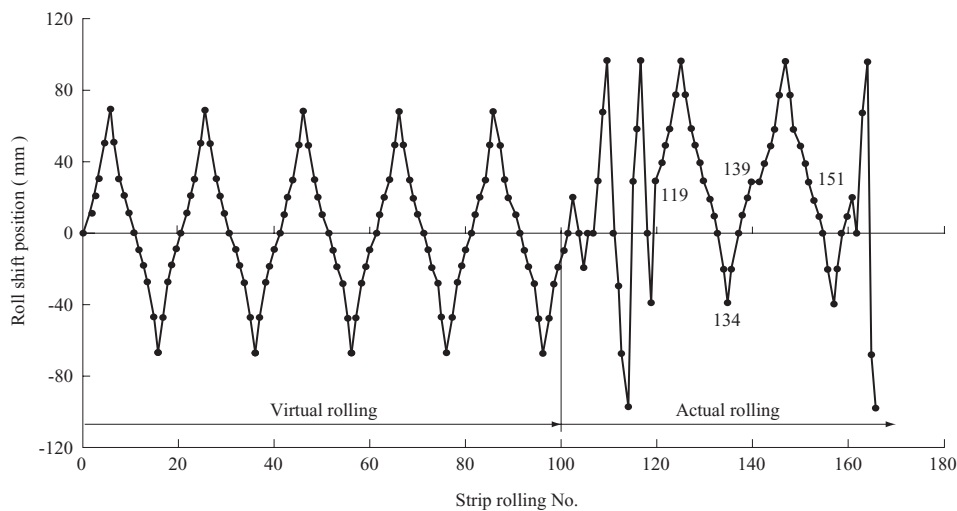

(Note) F5 stand

Fig. 9 Oscillation schedule (at F5 stand) for roll wear dispersion tests

strip was increased by 200 mm, from 950 mm to 1 150 mm corresponding to the 139 th strip, no “cat’s ear” (a shape like a cat’s ear formed at the strip edge when the strip width increases) occurred and the strip crown was normal, demonstrating that the shift oscillation helps realize schedule-free rolling.

For cold rolling mills, if strip shape control is focused on the edge drop portions, the taper work roll shift method, shown in Fig. 4-(a), may be adopted. In rolling with taper roll corner at the strip edge, in case of thin strip, strip breakage could occur at the downstream pass. Therefore, rolling with a taper corner roll is performed at the upstream pass, where the strip thickness is large, and mass flow in the width direction is more likely to occur, so that the control effect remains even after rolling at the downstream pass. Figure 11 shows a result of edge drop crown progress test with three-pass rolling. This figure shows the result of cold-rolling a strip width end with a taper corner roll having a diameter of 400 mm, and measuring the edge

drop strip crown control effect. Figure 11 shows the difference in thickness between the strip width center and a portion 7.5 mm inward from the strip width end in the width direction.

It can be seen from this figure that the evidence of the edge drop control effect at the upstream pass diminishes rapidly after normal rolling at the downstream pass, causing the edge drop control effect on the product to decrease; therefore, it is necessary to produce a control effect similar to that with edge up at the upstream pass. In rolling with taper work roll shift, it is necessary to adjust the taper positions more finely.

To reduce edge drop at the outermost edge, vertical roll mills were experimentally adopted to reduce edge drop in actual production mills.⁽⁷⁾

For multi-high cold rolling mills, the shape control performance is improved by the intermediate roll shift method because this method prevents the strip surface defect from being affected by work roll shift. With the intermediate roll shift method, the geometric shape

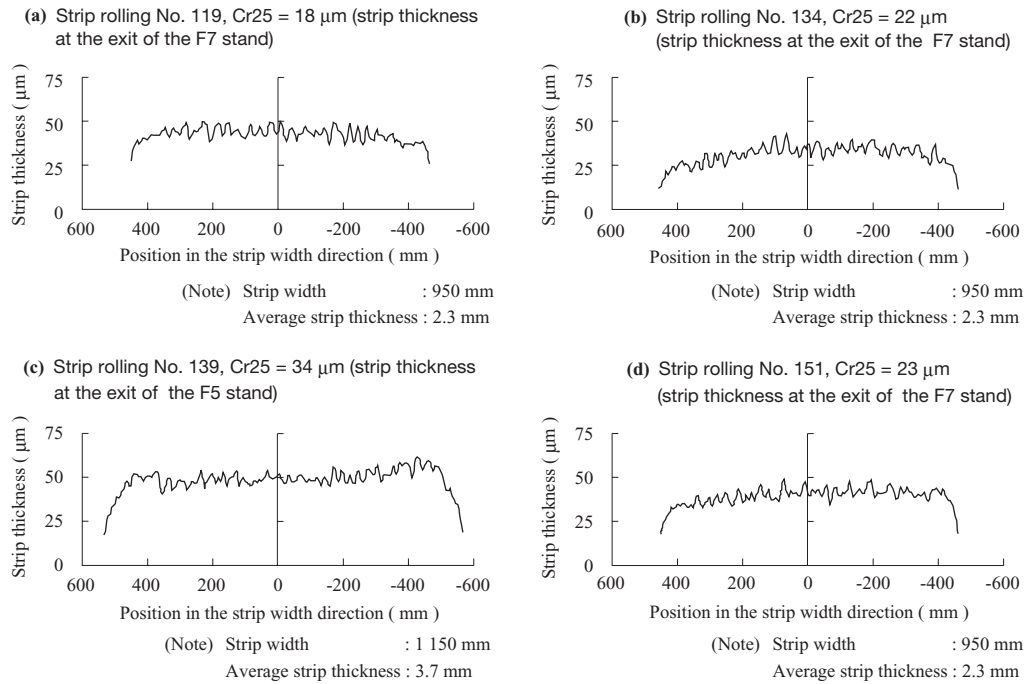
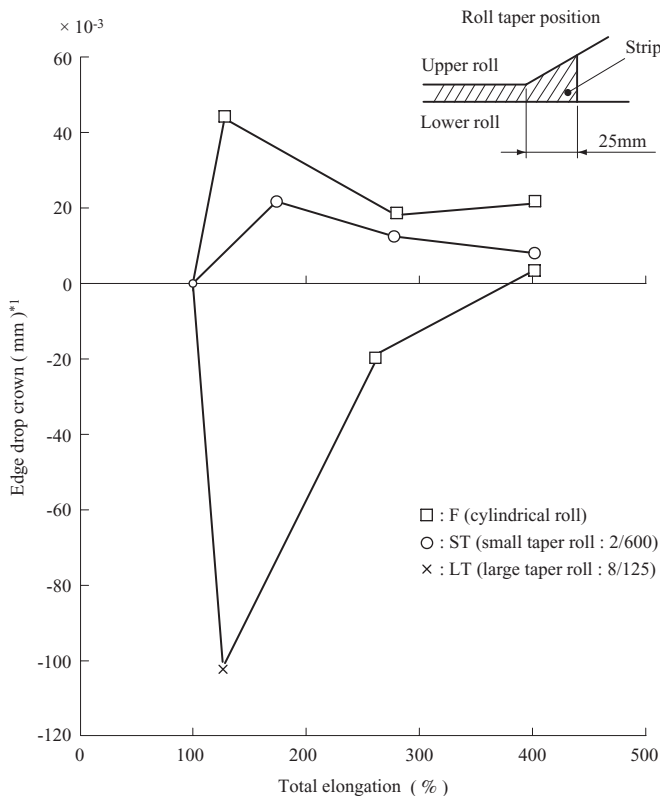

Fig. 10 Delivery strip profile and crown values from an actual stand



(Note) · Test rolling mill : 2HI mill $\phi 400 \times 350$ mm
 · Raw strip : slitted strip
 · Strip width : 150 mm
 · Strip thickness : 2.2 mm \rightarrow 0.55 mm (three-pass rolling)
 · Rolling force
 F-F-F : 960-920-970 MN
 *1. Difference in strip thickness between the strip center and a position 7.5 mm inward from the strip width end in the width direction

Fig. 11 Edge drop crown progress with 3 pass rolling

effect produced by the above-mentioned intermediate shift roll shape is a little difficult to transmit to strips because the bending stiffness of the work rolls is high. Accordingly, the shape control effect is produced by optimizing the shift roll shape with the elastic deformation effect on the roll taken into account. Table 2 and Fig. 12 show control effect comparison between the six-high rolling mill with the optimally shaped shift intermediate roll (another type of CNP® roll) and six-high rolling mill with normal shaped shift intermediate roll (shown in Fig. 4-(b)), using theoretical analysis.

A shifting device can be installed at either the operation side or drive side, depending on the workability and serviceability required by the customer. Roll shift shape control actuators are used more often than before because they are able to produce flexible control effects depending on the selected roll shape, and they can be installed on a large sized rolling mill such as hot steel plate mills.

2.3 Inflating roll method (Variable crown roll method)

As mentioned above, with a longer roll barrel length, the effect of WRB is less likely to transmit to the strip width center region in WRB shape control. The strip shape control effect can be maintained by combining the WRB method with the method by which a back-up roll is partially inflated in the roll barrel direction for shape control. If the shape control performance can be maintained by using an inflating roll as a back-up roll, it is possible to eliminate the need to process the work roll to form a convex-curved shape in strip center region. This type roll reduces the chance of sharp uneven contact between the strip and work roll, and is effective

Table 2 Calculation conditions for shape control of 6HI mill

Item	Unit	CNP® roll	Comparative example 1
Work roll diameter	mm	400	400
Intermediate roll diameter	mm	440	440
Back-up roll diameter	mm	1 200	1 200
Work roll barrel length	mm	1 420	1 420
Intermediate roll shape	—	0.2 mm, locally convex-curved	Fig. 4-(b) type
Maximum shift of the intermediate roll	mm	±125	0 to 250
Rolling force	kN	6 600	6 600
Strip width	kN	1 000	1 000
Nominal thickness of rolled strips	mm	0.5	0.5
Work roll bending load	kN	+ 400, - 200	+ 400, - 200
Intermediate roll bending load	kN	+ 400	+ 400

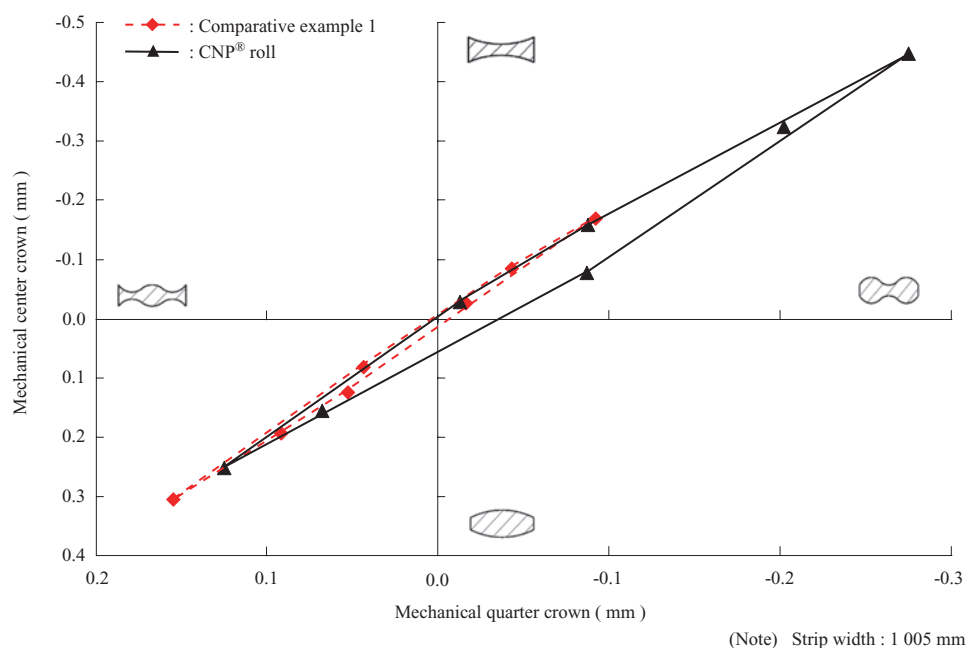
**Fig. 12** Characteristic in two dimensional strip shape with 6HI mill

especially when the quality of the strip surface needs to always be superior.

For rolling mills for small rolling loads, a variable crown roll (for example, a VC roll⁽⁸⁾) having a hydraulic chamber for inflation in the roll barrel length center, and a WRB roll can be used at the same time. **Figure 1** shows an example of the performance calculation with a four-high rolling mill ($\phi 480/\phi 1\ 220 \times 1\ 950$ mm) equipped with a VC roll having an inflation rate of 0.32 mm and a DCB. For shape control with a larger rolling force, IHI has developed and delivered its own TP (Taper-piston) rolls.

Figure 13 shows a TP roll. A TP roll consists of an arbor, sleeve, and taper piston, and adjusts the roll profile by hydraulically adjusting the taper piston position. The profile can be more freely adjusted by installing two pistons at each side. TP rolls are used for aluminum hot rolling mills whose back-up rolls have a

large barrel length.⁽⁹⁾

TP rolls can easily be installed in 2HI rolling mills (this type of mill is used in hot skin pass mills), in which shape control actuators cannot easily be installed because it is not possible to apply WRB. Because TP rolls can be installed as work rolls, the size and inflation are smaller than those achieved with the above-mentioned back-up rolls in aluminum hot rolling mills. However, because strips are directly contacted and affected by the changes in the roll profile, the shape control effect becomes larger. **Figure 14** shows an example of the measured inflation curve of a medium diameter TP roll with a diameter of 550 mm for 2HI.

2.4 Other methods

In wide strip mills for thin thickness, a pocket-like shape is more likely to occur because it is difficult to locally control shapes in random (asymmetrical) positions with the mechanical shape control actuators described

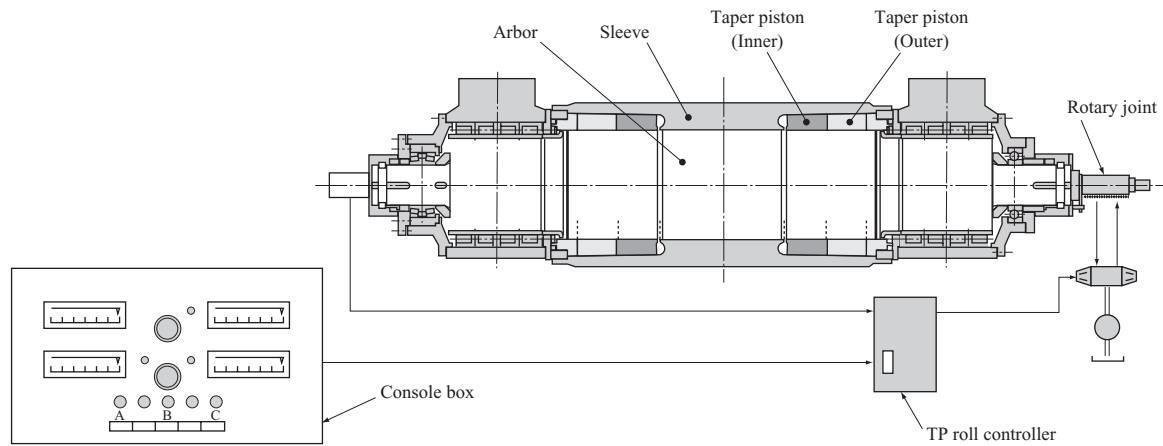

Fig. 13 Taper-piston roll⁽¹⁾

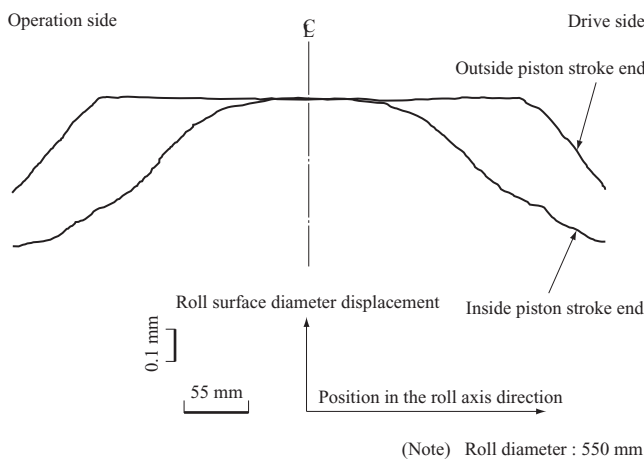

Fig. 14 Roll surface displacement in TP work roll with intermediate diameter

so far. In such cases, zone coolant or spot coolant (or heating) control is effective. Such control, which uses local thermal expansion and local contraction of a roll, is combined with a strip flatness sensor to form an automatic shape control system commonly used as an AFC (Automatic Flatness Control) system in rolling mills for nonferrous metals. For details, refer to the “Flatness Control System of Cold Rolling Process with Pneumatic Bearing Type Shape Roll” in this IHI Engineering Review.

Basically, shape control actuators for strip and plate rolling are operated and controlled based on the shape sensor outputs. Therefore, even with high-performance actuators, shape errors could occur owing to shape detection errors or feedback calculation errors. To prevent this, a tension leveler, which automatically and mechanically corrects strip flatness, may be adopted as a piece of final finishing equipment for thin strips. Furthermore, to increase its effect on extremely thin strips, a hydro tension leveler,⁽¹⁰⁾ which has a strip bending head with an extremely small curvature radius, may be adopted.

A differential speed rolling mill, which has a bottom roll that operates at a different speed from the top roll, reduces the rolling force, helping enhance productivity, and it provides benefits such as ① smaller minimum rolling thickness, ② improved strip shapes, and ③ finer microstructure grains. Making the differential speed ratio variable makes the rolling force variable, thus producing the shape control effect. From such a comprehensive perspective, the differential speed rolling mill shown in Fig. 15 was delivered. A differential gear system with planetary gears was adopted for this rolling mill, making it possible to select the appropriate differential speed ratio without increasing the total equipment motor power. It has been reported that in aluminum strip rolling for automobile sheet parts, the value “r” (Lankford value), a formability index value, has been significantly improved by adopting 4HI differential speed rolling mills.⁽¹¹⁾

For multi-high cluster mills, shape control is performed by combining the above-mentioned various shape control actuators.⁽¹²⁾

3. Conclusion

IHI has delivered various types of shape control

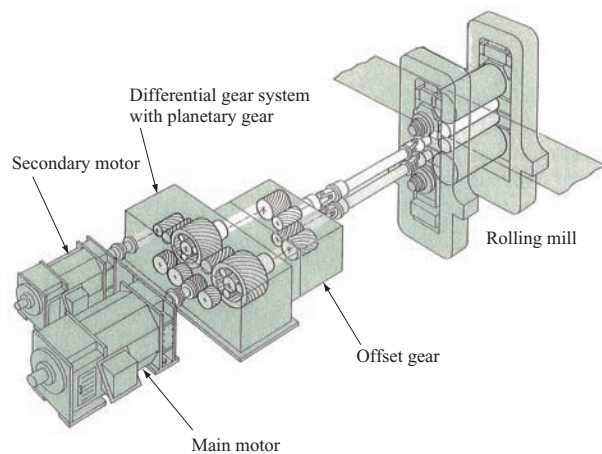

Fig. 15 Differential circumferential speed rolling mill

actuators for strips and plates. This paper has introduced the major types and their equipment and usage characteristics. It is recommended that methods such as the rolling bending method, shift roll method, or inflated roll method be adopted according to the usage of the rolling equipment. In hot steel rolling the shift roll method is adopted more often than before.

As described in this paper, various types of shape control actuators are available depending on the rolling production conditions and requirements. The authors intend to make full use of techniques introduced in this paper to meet customers' requests when installing rolling equipment.

The authors also intend to make every effort to further develop shape control mills.

REFERENCES

- (1) M. Kuchi et al.: Recent Aluminium Rolling Mill Design, Ishikawajima-Harima Engineering Review Vol.43 No.4 (2003.11) pp. 129-133
- (2) S. Tomita: Research and Development for Rolling and Production Process, CAMP-ISIJ Vol.17 No.2 (2004.3) pp. 258
- (3) S. Takatani et al.: Control System Development on Plate Rolling with Back-up Roll Bending Device, the 110th ISIJ Rolling Theory Committee NO 11 in the 110th ISIJ Rolling Theory Committee (1999.7)
- (4) H. Suzuki: Atsuenhyakuwa the1st edition Yokendo (2000) PP. 106-109
- (5) IHI: Patent Publicated Number 2 005-14 061 HONJO Hisashi et al.
- (6) M. Sato et al.: Strip Crown and Flatness Control for Hot Strip Mill, Ishikawajima-Harima Engineering Review Vol.44 No.5 (2004.9) pp. 352-357
- (7) N.Tazoe et al.: Edge drop control by hot strip edge between finishing mill stands, CAMP-ISIJ Vol.5 (1992) pp. 475-478
- (8) T. Masui et al.: Flatness Control Characteristics of Rolling Mill with Variable Crown Mill, Journal of the JSTP Vol.31 No.350 (1990) pp. 515-521
- (9) H. Kobayashi et al.: Application of TP Roll in Aluminium Hot Rolling Mill, Furukawa Electric Review No.89 (1991.12) pp. 152-159
- (10) S. Kawai et al.: Newly Developed Hydrostatic Tension Leveler, IHI Engineering Review Vol.14 No.2 (1981.4) pp. 101-109
- (11) T. Komatsubara et al.: Improvement of Formability in Al-Mg-Si Alloy Sheets by Asymmetric Warm Rolling, Furukawa-Sky Review No.3 (2007.4) pp. 25-30
- (12) T. Iwasaki et al.: Performance of 12-High Cluster Cold Mill with Small Diameter Work Rolls (X-Mill), Ishikawajima-Harima Engineering Review Vol.45 No.2 (2005.6) pp. 91-95